



KENYA SCHOOL OF GOVERNMENT

Empowering the Public Service

RESERVED FOR WOMEN

**INSTALLATION AND COMMISSIONING OF CAR
PARK SHADES**

TENDER NO. KSG/26/2017-2018

SUBMISSION DEADLINE: 23RD FEBRUARY 2018 AT 10.30A.M.

**P.O. BOX 23030 -00604
TEL: +254 02 4015000
NAIROBI, KENYA
www.ksa.ac.ke**

Table of Contents

SECTION A. INVITATION FOR TENDERS	
Section B. Instructions to Tenderers	4
The Tender Document	5
Submission of Tenders	11
Opening and Evaluation of Tenders	12
23 Technical and Financial Evaluations of Tenders	13
Award of Contract	16
29. Notification of Award	17
30. Signing of Contract	17
31. Performance Security	17
32. Corrupt Fraudulent Practices	18
Section C-General Conditions of Contract	19
SECTION D. SPECIAL CONDITIONS OF CONTRACT	24
SECTION E: - SCHEDULE OF REQUIREMENTS AND PRICE SCHEDULE INCLUSIVE OF ALL TAXES	25
SECTION F. TECHNICAL SPECIFICATIONS	26
VIII. SECTION G. QUALIFICATION QUESTIONNAIRE	31
SECTION G: SUMMARY EVALUATION PROCESS	32
Section H. Standard Tender Form	34
(ii) KSG BUSINESS QUESTIONNAIRE:	35
ii) Tender Security Form.....	40
iv) Contract Form	41
v) Performance Security Form	42
vi) Manufacturer's Authorization Form	43
vii) Tender security declaration form.....	44

TENDER NOTICE:

Date: 06/02/2018

Kenya School of Government Baringo invites Bids from eligible tenderers for the **Installation and Commissioning of car park shades**. Interested firms may download tender documents for free from www.ksg.ac.ke

Bidders who download the tender documents from the website should immediately email their names and contact details (cellphone number, email, and company name) to director.baringo@ksg.ac.ke for records and communication of any tender clarifications and addenda.

The tender is reserved for Persons with disabilities and they are required to attach YAGPO certificate from National Treasury.

Tenders should be in plain sealed envelopes, marked with the tender number on the right hand side corner and bearing no indication of the tenderer should be addressed to:

DIRECTOR GENERAL
KENYA SCHOOL OF GOVERNMENT,
P. O. Box 91-30400,
KABARNET

and dropped in the **Tender Box at the Administration Block at KSG Baringo**, or sent by post so as to reach the above address not later than **23RD February 2018 at 10.00 a.m.**

Submitted bids will be opened publicly immediately after the closing time in the Main Board Room in Administration Block, in the presence of the tenderers, or their representatives, who choose to attend.

Late bids will be returned unopened.

Price quoted must remain valid for one hundred and twenty (120) days from the opening date of the tender.

Kenya School of Government reserves the right to reject any tender with reasons for the rejection and does not bind itself to accept the lowest or any tender.

Section B. Instructions to Tenderers

Introduction

1. Eligible Tenderers

1.1 This Invitation for Tenders is open to pre-qualified tenderers as described in the tender documents. Successful tenderers shall complete the supply of materials and goods by the intended completion date specified in the tender documents.

1.2 Tenderers shall provide the qualification information statement that the tenderer (including all members of a joint venture and subcontractors) is not associated, or have been associated in the past, directly or indirectly, with a firm or any of its affiliates which have been engaged by KSG to provide consulting services for the preparation of the design, specifications, and other documents to be used for the procurement of the goods under this Invitation for tenders.

1.3 Tenderers shall not be under a declaration of ineligibility for corrupt and fraudulent practices.

2. Cost of Tendering

2.1 The Tenderer shall bear all costs associated with the preparation and submission of its tender, and KSG, will in no case be responsible or liable for those costs, regardless of the conduct or outcome of the tendering process.

The Tender Document

3. Contents

3.1 The tender document comprises the documents listed below and addenda issued in accordance with clause 6 of these instructions to tenders.

- (i) Invitation for Tenders
- (ii) Instructions to tenders
- (iii) General Conditions of Contract
- (iv) Special Conditions of Contract
- (v) Schedule of Requirements
- (vi) Technical Specifications
- (vii) Tender Form and Price Schedules

- (viii) Tender Security Form
- (ix) Contract Form
- (x) Performance Security Form
- (xi) Bank Guarantee for Advance Payment Form

(xii) Manufacturer's Authorization Form

3.2 The Tenderer is expected to examine all instructions, forms, terms, and specifications in the tender documents. Failure to furnish all information required by the tender documents or to submit a tender not substantially responsive to the tender documents in every respect will be at the tenderers risk and may result in the rejection of its tender.

4. Clarification of Documents

4.1 A prospective tenderer requiring any clarification of the tender document may notify KSG in writing or by cable (hereinafter, the term cable is deemed to include telex and facsimile) at the address indicated in the Invitation for tenders. KSG will respond in writing to any request for clarification of the tender documents, which it receives no later than ten (10) days prior to the deadline for the submission of tenders, prescribed by KSG. Written copies of KSG response (including an explanation of the query but without identifying the source of inquiry) will be sent to all prospective tenderers that have purchased the tender document.

5. Amendment of Documents

5.1 At any time prior to the deadline for submission of tenders, KSG, for any reason, whether at its own initiative or in response to a clarification requested by a prospective tenderer, may modify the tender documents by amendment / addendum.

5.2 All prospective candidates that have received the tender documents will be notified of the amendment in writing or by cable, and will be binding on them.

5.3 In order to allow prospective tenderers reasonable time in which to take the amendment into account in preparing their tenders, KSG, at its discretion, may extend the deadline for the submission of tenders.

Preparation of Tenders

6. Language of Tender

The tender prepared by the tenderer, as well as all correspondence and documents relating to the tender exchanged by the tenderer and KSG, shall be written in English language, provided that any printed literature furnished by the tenderer may be written in another language provided they are accompanied by an accurate English translation of the relevant passages in which case, for purposes of interpretation of the tender, the English translation shall govern.

7. Documents Comprising the Tender

7.1 The tender prepared by the tenderer shall comprise the following components:

(a) A Tender Form and a Price Schedule completed in accordance with paragraph 9, 10 and 11 below.

(b) Documentary evidence established in accordance with paragraph 12 that the tenderer is eligible to tender and is qualified to perform the contract if its tender is accepted;

(c) Documentary evidence established in accordance with paragraph 13 that the goods and ancillary services to be supplied by the tenderer are eligible goods and services and conform to the tender documents; and

(d) Tender security furnished in accordance with paragraph 14

8. Tender Form

8.1 The tenderer shall complete the Tender Form and the appropriate Price Schedule furnished in the tender documents, indicating the goods to be supplied, a brief description of the goods, their country of origin, quantity, and prices.

9. Tender Prices

9.1 The tenderer shall indicate on the appropriate Price Schedule the unit prices and
total
tender price

of the goods it proposes to supply under the contract.

9.2 Prices indicated on the Price Schedule shall include all duties and taxes payable in the country and charges for inland transportation, insurance, and other local costs incidental to delivery of the goods to their final destination; and

9.3 Prices quoted by the tenderer shall be fixed during the Tender's performance of the contract and not subject to variation on any account. A tender submitted with an adjustable price quotation will be treated as non-responsive and will be rejected, pursuant to paragraph 22.

10. Tender Currency

10.1 Prices shall be quoted in Kenya shilling unless otherwise specified in the appendix

to instruction to tenderers.

11. Tenderer's Eligibility and Qualifications.

11.1 Pursuant to paragraph 1 of section III, the tenderer shall furnish, as part of its tender, documents establishing the tenderers eligibility to tender and its qualifications to perform the contract if its tender is accepted.

11.2 The documentary evidence of the tenderers eligibility to tender shall establish to KSG's satisfaction that the tenderer, at the time of submission of its tender, is from an eligible source country as defined under paragraph I of section III.

11.3 The documentary evidence of the tenderers qualifications to perform the contract if its tender is accepted shall establish to KSG's satisfaction.

a) that, in the case of a tenderer offering to supply goods under the contract which the tenderer did not manufacture or otherwise produce, the tenderer has been duly authorized by the goods' Manufacturer or producer to supply the goods-

(b) that the tenderer has the financial, technical, and production capability necessary to perform the contract;

(c) that, in the case of a tenderer not doing business within Kenya, the tenderer is or will be (if awarded the contract) represented by an Agent in Kenya equipped, and able to carry out the Tenderers' maintenance, repair, and spare parts-stocking obligations prescribed in the Conditions of Contract and/or Technical Specifications and any other dispute that may arise.

12. Goods' Eligibility and Conformity to Tender Document.

13.1 Pursuant paragraph 2 of this section, the tenderer shall furnish, as part of its tender, documents establishing the eligibility and conformity to the tender documents of all goods, which the tenderer proposes to supply under the contract.

13.2 The documentary evidence of the eligibility of the goods shall consist of a

statement in the Price Schedule of the country of origin of the goods offered which shall be confirmed by a certificate of origin issued at the time of shipment.

13.3 The documentary evidence of conformity of the goods to the tender documents may be in the form

of literature, drawings, and data, and shall consist of:

- (a) a detailed description of the essential technical and performance characteristics of the goods;
- (b) a list giving full particulars, including available sources and current prices of spare parts, special tools, etc., necessary for the proper and continuing functioning of the goods for a period of two (2) years, following commencement of the use of the goods by KSG; and
- (c) a clause-by-clause commentary on KSG's Technical Specifications demonstrating substantial responsiveness of the goods to those specifications or a statement of deviations and exceptions to the provisions of the Technical Specifications.

13.4 For purposes of the commentary to be furnished pursuant to paragraph 13.3(c) above, the tenderer shall note that standards for workmanship, material, and equipment, as well as references to brand names or catalogue numbers designated by KSG in its Technical Specifications, are intended to be descriptive only and not restrictive. The tenderer may substitute alternative standards, brand names, and/or catalogue numbers in its tender, provided that it demonstrates to KSG's satisfaction that the substitutions ensure substantial equivalence to those designated in the Technical Specifications.

14. Tender Security

14.1 The tenderer shall furnish, as part of its tender, a tender security for the amount specified in the Invitation to tender.

14.2 The tender security is required to protect KSG against the risk of Tenderer's conduct, which would warrant the security's forfeiture, pursuant to paragraph 14/7

14.3 The tender security shall be denominated in Kenya Shillings or in another freely convertible currency, and shall be in the form of a bank guarantee, a

bank draft issued by a reputable bank located in Kenya or abroad, or an insurance company guarantee from any of the IRA approved companies, in the form provided in the tender documents and valid for thirty (30) days beyond the validity of the tender.

14.4 Any tender not secured in accordance with paragraph 14.1 and 14.3 will be rejected by KSG as non-responsive, pursuant to paragraph 22.

14.5 Unsuccessful Tenderer's tender security will be discharged or returned as promptly as possible as but not later than thirty (30) days after the expiration of the period of

tender validity prescribed by KSG.

14.6 The successful Tenderer's tender security will be discharged upon the tenderer signing the contract, pursuant to paragraph 30, and furnishing the performance

security, pursuant to paragraph 31.

14.7 The tender security may be forfeited:

(a) If a tenderer withdraws its tender during the period of tender validity specified by KSG on the Tender Form; or

(b) In the case of a successful tenderer, if the tenderer fails:

(i) To sign the contract in accordance with paragraph 30

Or

(ii) To furnish performance security in accordance with paragraph 31.

(iii) **TENDER SECURITY IS NOT APPLICABLE**

15. Validity of Tenders

15.1 Tenders shall remain valid for 120 days after date of tender opening prescribed by KSG, pursuant to paragraph 18. A tender valid for a shorter period shall be rejected by KSG as non-responsive.

15.2 In exceptional circumstances, KSG may solicit the Tenderer's consent to an extension of the period of validity. The request and the responses thereto shall be made in writing. The tender security provided under paragraph 14 shall also be suitably extended. A tenderer may refuse the request without forfeiting its tender security. A tenderer granting the request will not be required nor permitted to modify its tender.

16. Format and Signing of Tender

16.1 The tenderer shall prepare two copies of the tender, clearly marking each "**ORIGINAL TENDER**" and "**COPY OF TENDER**," as appropriate/ In the event of any discrepancy between them, the original shall govern.

16.2 The original and all copies of the tender shall be typed or written in indelible ink and shall be signed by the tenderer or a person or persons duly authorized to bind the tenderer to the contract. The latter authorization shall be indicated by written power-of-attorney accompanying the tender. All pages of the tender, except for un-amended printed literature, shall be initialed by the person or persons signing the tender.

16.3 The tender shall have no interlineation, erasures, or overwriting except as necessary to correct errors made by the tenderer, in which case such corrections shall be initialed by the person or persons signing the tender.

Submission of Tenders

17. Sealing and Marking of Tenders

17.1 The tenderer shall seal the original and each copy of the tender in separate envelopes, duly marking the envelopes as "**ORIGINAL**" and "**COPY**" The envelopes shall then be sealed in an outer envelope.

17.2 The inner and outer envelopes shall:

(a) Be addressed to KSG at the following address:

Director General,
KENYA SCHOOL OF GOVERNMENT,
P.O BOX 91-30400-90200,
KABARNET

(b) Bear, KSG/26 /2016/2017, the Invitation for tenders (IFT), and the words. "DO NOT OPEN BEFORE," Thursday 4th February 2016. at 10.00 AM

17.3 The inner envelopes shall also indicate the name and address of the tenderer to enable the tender to be returned unopened in case it is declared "late"

17.4 If the outer envelope is not sealed and marked as required by paragraph 17.2, KSG will assume no responsibility for the tender's misplacement or premature opening

18. Deadline for Submission of Tenders

18.1 Tenders must be received by KSG at the address specified under paragraph

17.2 not later than 10.00 am on Thursday **23RD FEBRUARY 2018**

18.2 KSG may, at its discretion, extend this deadline for the submission of

tenders by amending the tender documents in accordance with paragraph 6, in which case all rights and obligations of KSG and candidates previously subject to the deadline will thereafter be subject to the deadline as extended.

19. Modification and Withdrawal of Tenders

19.1 The tenderer may modify or withdraw its tender after the tender's submission,

provided that written notice of the modification, including substitution or withdrawal of the tenders, is received by KSG prior to the deadline prescribed for submission of tenders. 19.2 The Tenderer's modification or withdrawal notice shall be prepared, sealed, marked,

and dispatched in accordance with the provisions of paragraph 17. A withdrawal notice may also be sent by cable, but followed by a signed confirmation copy, post marked not later than the deadline for submission of tenders.

19.3 No tender may be modified after the deadline for submission of tenders.

19.4 No tender may be withdrawn in the interval between the deadline for submission of tenders and the expiration of the period of tender validity specified by the tenderer on the Tender Form. Withdrawal of a tender during this interval may result in the Tenderer's forfeiture of its tender security, pursuant to paragraph 14/7/

Opening and Evaluation of Tenders

20. Opening of Tenders

20.1 KSG will open all tenders in the presence of tenderers' representatives who choose to attend, at **KENYA SCHOOL OF GOVERNMENT MAIN BOARD ROOM IN ADMINISTRATION BLOCK** Baringo campus, Baringo, in the Boardroom.

The tenderers' representatives who are present shall sign a register evidencing their attendance.

20.2 The tenderers' names, tender modifications or withdrawals, tender prices, discounts, and the presence or absence of requisite tender security and such other details as KSG, at its discretion, may consider appropriate, will be announced at the opening.

20.2 KSG will prepare minutes of the tender opening.

21. Clarification of Tenders

21.1 To assist in the examination, evaluation and comparison of tenders KSG may, at its discretion, ask the tenderer for a clarification of its tender. The

request for

clarification and the response shall be in writing and no change in the prices or substance of the tender shall be sought, offered, or permitted.

21.2 Any effort by the tenderer to influence KSG in its tender evaluation, tender comparison or contract award decisions may result in the rejection of the tenderers' tender.

22. Preliminary Examination

22.1 Prior to the detailed Technical and Financial evaluation, KSG will determine the substantial

responsiveness of each Tender. For purposes of this tender, a substantially responsive Tender is one that conforms to the requirements of Preliminary Evaluation/ KSG's determination of a Tender's responsiveness is to be based on the contents of the Tender itself without recourse to extrinsic evidence.

22.2 . KSG will examine the Tenders to determine whether they conform to the Preliminary Evaluation Criteria set out in the Summary of Evaluation Process.

22.3 Notwithstanding the contents of the foregoing sub-paragraphs, if a Tender is not substantially responsive, it will be rejected at the earliest stage of evaluation by KSG and cannot subsequently be made responsive by the Tenderer by correction of any non-conformity.

22.4 KSG may waive any minor deviation in a Tender that does not materially depart from the requirements of the goods and or services set out in the Tender Document.

22.5 Such minor deviation -shall be quantified to the extent possible, shall be taken into account in the evaluation process, and, shall be applied uniformly and consistently to all qualified Tenders duly received by KSG.

23 Technical and Financial Evaluations of Tenders

23.1 Technical evaluation of tenders

23.1.1 KSG will evaluate and compare the Tenders that have been determined to be substantially responsive in compliance to the Technical requirements set out in the Tender Document as set out in the Summary of Evaluation Process.

23.2 Financial Evaluation of Tenders

23.2.1 Upon completion of the preliminary and technical evaluation, KSG shall conduct a Financial Evaluation and comparison as set out in the Summary of Evaluation Process. 23.2.2 Where other currencies are used, KSG will convert those currencies to the same currency using the selling exchange rate ruling on the date of tender closing provided by the Central Bank of Kenya.

23.2.3 Arithmetical errors will be rectified on the following basis - if there is a discrepancy between the unit price and the total price that is obtained by multiplying the unit price and quantity, the unit price shall prevail, and the total price shall be corrected. If there is a discrepancy between words and figures, the amount in words will prevail.

APPENDIX TO INSTRUCTION TO TENDERERS

PRE-TENDER INSTRUCTIONS TO TENDERERS

There will be a **mandatory** pre site visit to be held on **8th February 2018. At 10:00AM**

Failure to attend this Pretender conference will lead to automatic disqualification of the tenderer.

Contractors representatives name.....

Signature.....Date.....

Client or Project Manager's representative..... Signature and

Stamp.....Date.....

9 Evaluation Criteria

No.	Requirements	Responsive or Not Responsive
MR1	Must Submit a copy of certificate of Registration/Incorporation	
MR2	Must Submit a copy of a valid Tax Compliance certificate from Kenya Revenue Authority	
MR3	Must Fill the BQ in the format provided	
MR4	Must Fill the Form of Tender in the Format provided	
MR5	Signed and stamped statement of Verification that you are not debarred in matters of Public procurement	
MR6	Must submit a dully filled up tender securing declation form in format provided	
MR7	Must submit a dully filled up Confidential Business Questionnaire in format provided	
MR8	Tender validity period 120 Days	
MR9	Must sign, serialize and stamp on all pages	
MR10	Dully filled and signed Business questionnaire	
MR11	Latest CR12 (within last 3 months)	
MR12	Must provide a copy of NCA registration Certificate (NCA 4 and above) and annual practicing certificate	
MR13	Signed site visit form	

TECHNICAL SPECIFICATION COMPLIANCE

	Parameter		Marks
	Conformity with Tender specifications As per drawings		
a	Roof Material	100% waterproof shapnet material	5
b	Size of one Set	5.8m x 5.3m x 2.6m	5
c	Apex Height	< or = 4.1m	5
d	No of Cars per Set	2	5
e	Colour	Green	5
f	Base Structure	Made of 4" Round or Square tubes or equivalent	5
g	Roof Structure	Made of 1.5" and 1" Round or square	5
h	Drawings/Brochures	Provide Brochures' for the Car Shade	15
i	Implementation plan/schedule	Provide work programme	5
3	Other Technical Requirements		
a	CV for Key personnel (Team Leader)	Diploma in Structural Engineering and over 10 years' experience (Each 5 marks for Diploma and 10 marks for experience) 5 marks for less than 10 years' experience.	15

b	Similar works done (three) each 5 marks)	Proof required. Either through Signed contracts or Local Purchase Orders	15
		TOTAL	100

23.2.4 The Tenderer will be promptly notified of the correction of the arithmetical error(s). If the Tenderer does not accept the correction of the error(s), its Tender will stand rejected, and its Tender Security automatically forfeited.

24. Contacting Kenya School of Government

24.1 Subject to paragraph 21, no tenderer shall contact KSG on any matter relating to its tender, from the time of the tender opening to the time the contract is awarded.

24.2 Any effort by a tenderer to influence KSG in its decisions on tender evaluation, tender comparison, or contract award may result in the rejection of the Tenderer's tender's bid proposal.

Award of Contract

25. Post-qualification

25.1 In the absence of pre-qualification, KSG will determine to its satisfaction whether the tenderer that is selected as having submitted the lowest evaluated responsive tender is qualified to perform the contract satisfactorily.

25.2 The determination will take into account the Tenderer's financial, technical, and production capabilities. It will be based upon an examination of the documentary evidence of the Tenderer's qualifications submitted by the tenderer, pursuant to paragraph 12.3, as well as such other information as KSG deems necessary and appropriate.

25.3 An affirmative determination will be a prerequisite for award of the contract to the tenderer/ A negative determination will result in rejection of the Tenderer's tender, in which event KSG will proceed to the next lowest evaluated tender to make a similar determination of that Tenderer's capabilities to perform satisfactorily/

26. Award Criteria

26.1 Subject to paragraph 10,23 and 28 KSG will award the contract to the successful tenderer(s) whose tender has been determined to be substantially responsive and has been determined to be the lowest evaluated tender, provided further that the tenderer is determined to be qualified to perform the

contract satisfactorily.

27. Kenya School of Government's Right to Vary quantities

27.1 KSG reserves the right at the time of contract award to increase or decrease the quantity of goods originally specified in the Schedule of requirements without any change in unit price or other terms and conditions.

28. KSG Reserves Right to Accept or Reject Any or All Tenders

28.1 KSG reserves the right to accept or reject any tender, and to annul the tendering process and reject all tenders at any time prior to contract award, without thereby incurring any liability to the affected tenderer or tenderers or any obligation to inform the affected tenderer or tenderers of the grounds for KSG's action.

29. Notification of Award

29.1 Prior to the expiration of the period of tender validity, KSG will notify the successful tenderer in writing that its tender has been accepted.

29.2 The notification of award will constitute the formation of the Contract.

29.3 Upon the successful Tenderer's furnishing of the performance security pursuant to paragraph 31, KSG will promptly notify each unsuccessful Tenderer and will discharge its tender security, pursuant to paragraph 14.

30. Signing of Contract

30.1 At the same time as KSG notifies the successful tenderer that its tender has been accepted, it will send the tenderer the Contract Form provided in the tender documents, incorporating all agreements between the parties.

30.2 Within fourteen (14) days of receipt of the Contract Form, the successful tenderer shall sign and date the contract and return it to KSG.

31. Performance Security

31.1 Within fourteen (14) days of the date of notification of award from KSG, the successful Tenderer shall furnish KSG with a Performance Security which shall be either one or a combination of the following:

a) An original Bank Guarantee that is strictly in the form and content as prescribed in the Performance Security Form (Bank Guarantee) in the Tender Document. .

31.2 The Performance Security shall be issued by a commercial bank licensed by the Central Bank of Kenya. The bank must be located in Kenya.

31.3 The successful Tenderer shall furnish a Performance Security being the sum of ten percent (10%) of the contract price.

31.4 KSG shall seek authentication of the Performance Security from the issuing bank. It is the responsibility of the successful Tenderer to sensitize its issuing bank on the need to respond directly and expeditiously to queries from KSG. The period for response shall

not exceed five (5) days from the date of KSG's query/ Should there be no conclusive response by the Bank within this period, such successful Tenderer's Performance Security may be deemed as invalid.

31.5 Failure of the successful Tenderer to furnish an authentic Performance Security, the award shall be annulled and the Tender Security forfeited, in which event KSG may notify the next lowest evaluated Tenderer that it's Tender has been accepted.

32. Corrupt Fraudulent Practices

32.1 KSG requires that tenderers observe the highest standard of ethics during the procurement process and execution of contracts. In pursuance of this policy, KSG:-

(a) Defines, for the purposes of this provision, the terms set forth below as follows:

(i) "corrupt practice" means the offering, giving, receiving or soliciting of anything of value to influence the action of a public official in the procurement process or in contract execution; and

(ii) "fraudulent practice" means a misrepresentation of facts in order to influence a procurement process or the execution of a contract to the

detriment of KSG, and includes collusive practice among tenderer (prior to or after tender submission) designed to establish tender prices at artificial non-competitive levels and to deprive KSG of the benefits of free and open competition;

(b) will reject a proposal for award if it determines that the tenderer recommended for award has engaged in corrupt or fraudulent practices in competing for the contract in question;

(c) will declare a firm ineligible, either indefinitely or for a stated period of time, to be awarded any contract if it at any time determines that the firm has engaged in corrupt or fraudulent practices in competing for, or in executing, a contract.

(d) 32.2 Furthermore, tenderers shall be aware of the provision stated in the General Conditions of Contract.

Section C-General Conditions of Contract

1. Definitions

1.1 In this Contract, the following terms shall be interpreted as indicated:

- (a) **"The Contract"** means the agreement entered into between KSG and the tenderer, as recorded in the Contract Form signed by the parties, including all attachments and appendices thereto and all documents incorporated by reference therein.
- (b) **"The Contract Price"** means the price payable to the tenderer under the Contract for the full and proper performance of its contractual obligations.
- (c) **"The Goods"** means all of the equipment, machinery, and/or other materials, which the tenderer is required to supply to KSG under the Contract.
- (d) **"KSG"** means **KENYA SCHOOL OF GOVERNMENT**, which is the organization purchasing the Goods under this Contract.
- (e) **"The tenderer"** means the individual or firm supplying the Goods under this Contract.

2. Application

2.1 These General Conditions shall apply in all Contracts made by KSG for the procurement of goods.

3. Country of Origin

3.1 For purposes of this Clause, "origin" means the place where the Goods were mined, grown, or produced.

3.2 The origin of Goods is distinct from the nationality of the tenderer.

4. Standards

4.1 The Goods supplied under this Contract shall conform to the standards mentioned in the Technical Specifications.

5. Use of Contract Documents and Information

5.1 The Candidate shall not, without KSG's prior written consent, disclose the

Contract, or 19

any provision thereof, or any specification, plan, drawing, pattern, sample, or information furnished by or on behalf of KSG in connection therewith, to any person other than a person employed by the tenderer in the performance of the Contract.

5.2 The tenderer shall not, without KSG's prior written consent, make use of any document or information enumerated in paragraph 5.1 above.

5.3 Any document, other than the Contract itself, enumerated in paragraph 5.1 shall remain the property of KSG and shall be returned (all copies) to KSG on completion of the Tenderer's performance under the Contract if so required by KSG/

6. Patent Rights

6.1 The tenderer shall indemnify KSG against all third-party claims of infringement of patent, trademark, or industrial design rights arising from use of the Goods or any part thereof in Kenya.

7. Performance Security

7.1 Within fourteen (14) days of receipt of the notification of Contract award, the successful tenderer shall furnish to KSG the performance security in the amount specified in Special Conditions of Contract.

7.2 The proceeds of the performance security shall be payable to KSG as compensation for any loss resulting from the Tenderer's failure to complete its obligations under the Contract.

7.3 The performance security shall be denominated in the currency of the Contract, or in a freely convertible currency acceptable to KSG and shall be in the form of a bank guarantee or an irrevocable letter of credit issued by a reputable bank located in Kenya or abroad, acceptable to KSG, in the form provided in the tender documents.

7.4 The performance security will be discharged by KSG and returned to the Candidate not later than thirty (30) days following the date of completion of the Tenderer's performance obligations under the Contract, including any warranty obligations, under

the Contract.

8. Inspection and Tests

8.1 KSG or its representative shall have the right to inspect and/or to test the Goods to confirm their conformity to the Contract specifications. KSG shall notify the tenderer in writing, in a timely manner, of the identity of any representatives retained for these purposes.

8.2 The inspections and tests may be conducted on the premises of the tenderer or its subcontractor(s), at point of delivery, and/or at the Goods' final destination/ If conducted on the premises of the tenderer or its subcontractor(s), all reasonable facilities and assistance, including access to drawings and production data, shall be furnished to the inspectors at no charge to KSG. 8.3 Should any inspected or tested Goods fail to conform to the Specifications, KSG may reject the Goods, and the tenderer shall either replace the rejected Goods or make alterations necessary to meet specification requirements free of cost to KSG.

8.4 KSG 's right to inspect, test and, where necessary, reject the Goods after the Goods' arrival shall in no way be limited or waived by reason of the Goods having previously been inspected, tested, and passed by KSG or its representative prior to the Goods' delivery.

8.5 Nothing in paragraph 8 shall in any way release the tenderer from any warranty or other obligations under this Contract.

9. Packing

9.1 The tenderer shall provide such packing of the Goods as is required to prevent their damage or deterioration during transit to their final destination, as indicated in the Contract.

9.2 The packing, marking, and documentation within and outside the packages shall comply strictly with such special requirements as shall be expressly provided for in the Contract.

10. Delivery and Documents

10.1 Delivery of the Goods shall be made by the tenderer in accordance with the terms specified by KSG in its Schedule of Requirements and the Special Conditions of Contract.

11. Insurance

11.1 The Goods supplied under the Contract shall be fully insured against loss or damage incidental to manufacture or acquisition, transportation, storage, and delivery in the manner specified in the Special conditions of contract

12. Payment 12.1 The method and conditions of payment to be made to the tenderer under this Contract shall be

specified in Special Conditions of Contract.

12.2 Payments shall be made promptly by KSG as specified in the contract.

13. Prices

13.1 Prices charged by the tenderer for Goods delivered and Services performed under the Contract shall not, with the exception of any price adjustments authorized in Special Conditions of Contract, vary from the prices by the tenderer in its tender.

14. Assignment

14.1 The tenderer shall not assign, in whole or in part, its obligations to perform under this Contract, except with KSG's prior written consent/

15. Subcontracts

15.1 The tenderer shall notify KSG in writing of all subcontracts awarded under this Contract if not already specified in the tender. Such notification, in the original tender or later, shall not relieve the tenderer from any liability or obligation under the Contract.

16. Termination for Default

16.1 KSG may, without prejudice to any other remedy for breach of Contract, by written notice of default sent to the tenderer, terminate this Contract in whole or in part:

- (a) if the tenderer fails to deliver any or all of the Goods within the period(s) specified in the Contract, or within any extension thereof granted by KSG.
- (b) if the tenderer fails to perform any other obligation(s) under the Contract.
- (c) if the tenderer, in the judgment of KSG has engaged in corrupt or fraudulent practices in competing for or in executing the Contract.

16.2 In the event KSG terminates the Contract in whole or in part, it may procure, upon such terms and in such manner as it deems appropriate, Goods similar to those undelivered, and the tenderer shall be liable to KSG for any excess costs for such similar Goods.

17. Liquidated Damages

17.1 If the tenderer fails to deliver any or all of the goods within the period(s) specified in the contract, KSG shall, without prejudice to its other remedies under the contract, deduct from the contract prices liquidated damages sum equivalent to 0.5% of the delivered price of the delayed goods

up to a maximum deduction of 10% of the delayed goods. After this the tenderer may consider termination of the contract.

18. Resolution of Disputes

18.1 KSG and the tenderer shall make every effort to resolve amicably by direct informal negotiation any disagreement or dispute arising between them under or in connection with the contract.

18.2 If, after thirty (30) days from the commencement of such informal negotiations both parties have been unable to resolve amicably a contract dispute, either party may require adjudication in an agreed national or international forum, and/or international arbitration.

19. Language and Law

19.1 The language of the contract and the law governing the contract shall be English language and the Laws of Kenya respectively unless otherwise stated.

20. Force Majeure

20.1 The tenderer shall not be liable for forfeiture of its performance, security, or termination for default if and to the extent that its delay in performance or other failure to perform its obligations under the Contract is the result of an event of Force Majeure.

SECTION D. SPECIAL CONDITIONS OF CONTRACT

General

Special Conditions of Contract supplement the General Conditions of Contract. Whenever there is a conflict, the provisions herein shall prevail over those in the General Conditions of Contract.

SCC 1. Delivery and Documents

The goods shall be delivered as per need basis.

SCC 2. Payment

One Hundred percent (100%) of the contract price of the materials and goods delivered shall be paid upon the delivery, inspection, testing and acceptance of the works by the KSG.

SCC 3:- Price Variations

No price adjustments are allowed in the contract.

SCC 4:- Performance Security

A performance security of a value of 10% of the contract value shall be furnished. **SCC 6:-Delivery Point**

There shall be one (1) delivery point KENYA SCHOOL OF GOVERNMENT

Specify mode of payment

Submit certificate/ letter from the official local distributor of the brand name product (computers/ photocopier/printer/ UPS) authorizing the bidder to supply the product locally (in Kenya).

Specify delivery period from the time of issuance of order or L/C.

SECTION E: - SCHEDULE OF REQUIREMENTS AND PRICE SCHEDULE INCLUSIVE OF ALL TAXES

Sn	Item	UNIT	Qty	Unit Cost	Total Cost	Country of Origin
1	Car parking Shades Size 5.8m x 5.3m x 2.6m height with 4.1m Apex height	Set	20			
	Total cost of the shades					
	ADD 16% VAT					
	Grand Total					

NB: Please note Delivery period is of essence and must be clearly stated.
 Having read, examined and understood the Tender Document including all Addenda, receipt of which we hereby acknowledge, we, the undersigned Tenderer, offer to supply, deliver, install and commission (the latter two where applicable) (Insert goods description) for the sum of..... (Total tender price in words and figures) or such other sums as may be ascertained in accordance with the schedule of prices inserted by me/ us above.

Name of _____ Tenderer
 Name and _____ Capacity of
 authorised person signing the Tender _____
 Signature of authorised person signing the Tender _____
 Stamp of Tenderer _____

SECTION F. TECHNICAL SPECIFICATIONS

GENERAL

1. These specifications describe the basic requirements for goods .Tenderers are requested to submit with their offers the detailed specifications, Samples drawings, catalogues, etc. for the products they intend to supply.

2. All the dimensions of the goods to be supplied shall not be less than those required in these specifications. Deviations from the basic requirements, if any shall be explained in detail in writing with the offer, with supporting data such as calculation sheets, etc.

KSG reserves the right to reject the products, if such deviations shall be found critical to the use and operation of the products.

3. The tenderers are requested to present information along with their offers as follows:

- i) Shortest possible delivery period of each product.
- ii) Information on manufacturers including their names and addresses.

Detailed Technical Specifications

All the goods to be supplied must conform to the following specifications.

1. DESCRIPTION: CAR PARK SHADES

DESCRIPTION: CAR PARK SHADES			
Bidder's SPECIFICATION			
Specification	Requirement	Bidders response	Annotation of Reference Doc
Roof Material	100% waterproof shapnet material	(Y/N)	
Size of one Set	5.8m x 5.3m x 2.6m	(Y/N)	
Apex Height	< or = 4.1m	(Y/N)	
No of Cars per Set	2	(Y/N)	
Colour	Preferably Green	(Y/N)	
Base Structure	Made of 4" Round or Square tubes or equivalent	(Y/N)	
Roof Structure	Made of 1.5" and 1" Round or square tubes.	(Y/N)	
Brochures for the Shades quoted for to be provided			

DRAWINGS

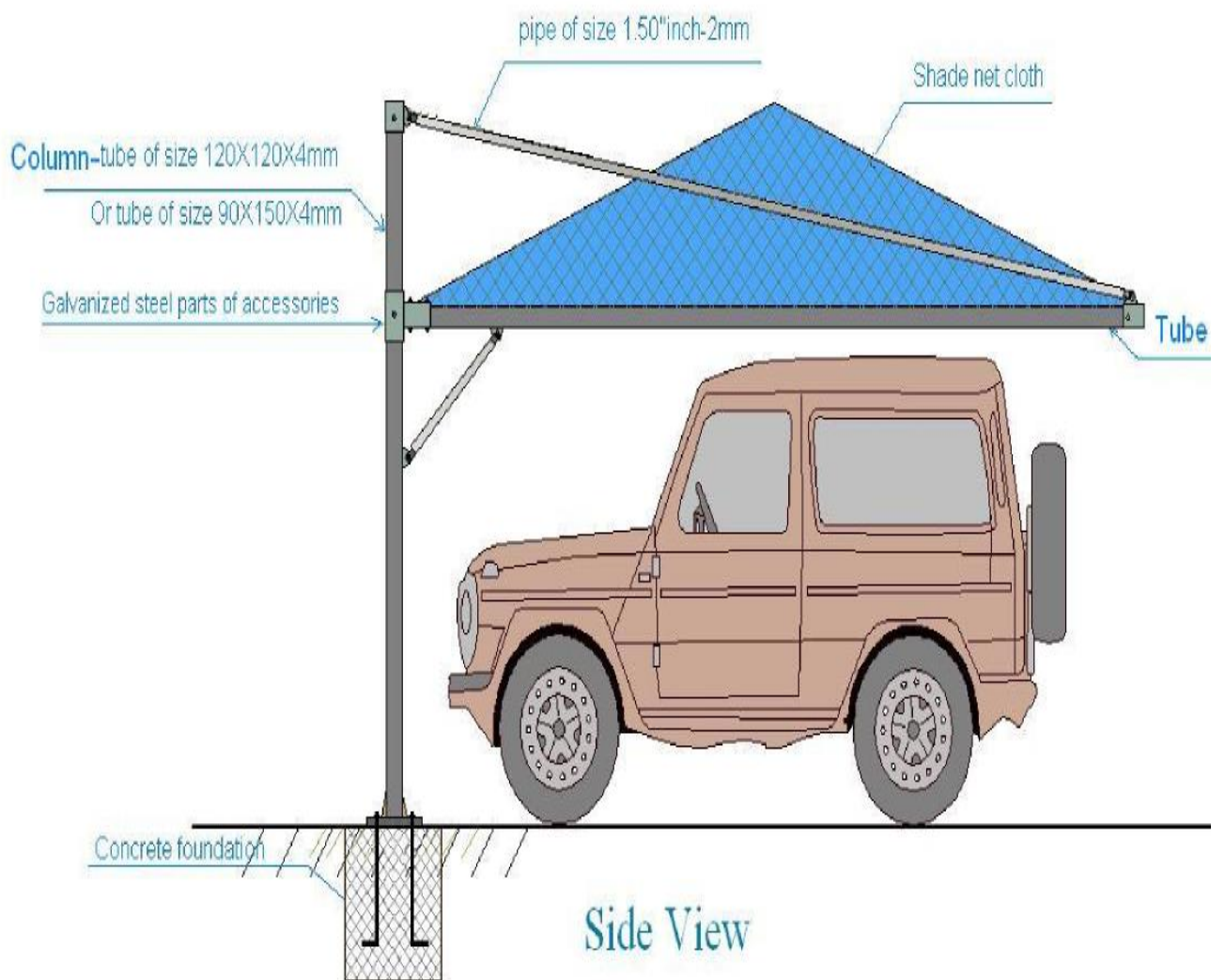

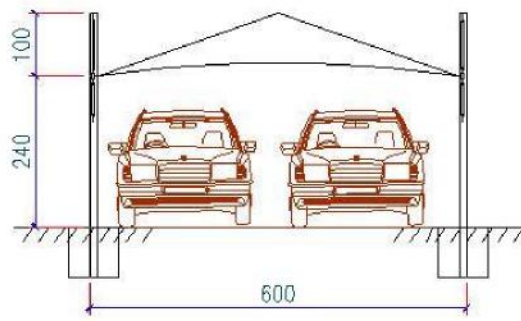

Front View

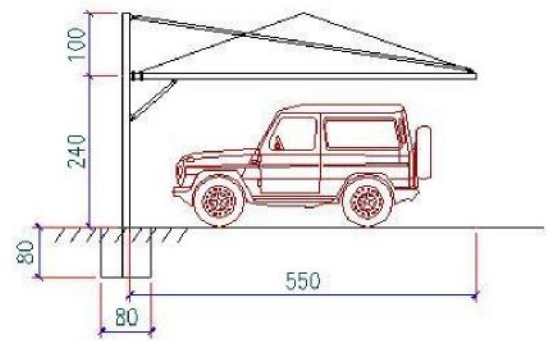

Side View

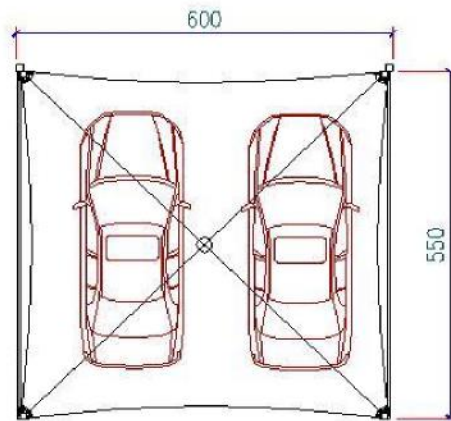

Top View

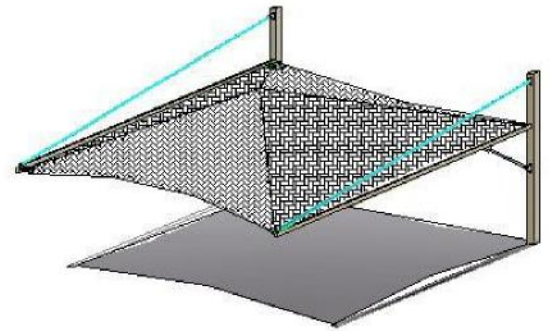

Isomeric View

Section H. Standard Tender Form

i) Form of Tender

Date: _____ Tender No:

..... To: DIRECTOR GENERAL

KENYA SCHOOL OF GOVERNMENT

P.O. BOX 91-30400,

BARINGO

Gentlemen and/or Ladies:

1. Having examined the tender documents.....[insert numbers] the receipt of which is hereby duly acknowledged, we, the undersigned, offer to supply and deliver

[description of goods] in conformity with the said tender documents for the sum of.....[total tender amount in words and figures] or such other sums as may be ascertained in accordance with the Schedule of Prices attached herewith and made part of this Tender.

2. We undertake, if our Tender is accepted, to deliver the goods in accordance with the delivery schedule specified in the Schedule of Requirements.

3. If our Tender is accepted, we will obtain the guarantee of a bank in a sum equivalent to percent of the Contract Price for the due performance of the Contract, in the form prescribed by KENYA SCHOOL OF GOVERNMENT.

4/ We agree to abide by this Tender for a period of0//[number] days from the date fixed for tender opening of the Instructions to tenderers, and it shall remain binding upon us and may be accepted at any time before the expiration of that period.

5. Until a formal Contract is prepared and executed, this Tender, together with your written acceptance thereof and your notification of award, shall constitute a binding Contract between us.

6. We understand that you are not bound to accept the lowest or any tender you may receive. Dated this day of 20 .

.....

[signature] [in the capacity of]

Duly authorized to sign tender for and on behalf of

(ii) BUSINESS QUESTIONNAIRE:

You are requested to give the particulars indicated in Part 1 and either Part 2 (a), 2 (b) or 2 (c) and 2 (d) whichever applies to your type of business.

You are advised that it is a serious offence to give false information on this Form.

Part 1 – General

Business Name

Location of business premises; Country/Town.....

Plot No..... Street/Road

Postal Address..... Tel No.....

Nature of Business.....

Current Trade Licence No..... Expiring date.....

Maximum value of business which you can handle at any time: K. pound.....

Name of your bankers.....

Branch.....

Part 2 (a) – Sole Proprietor

Your name in full..... Age.....

Nationality..... Country of Origin.....

*Citizenship details

Part 2 (b) – Partnership

Give details of partners as follows:

	Name in full	Nationality	Citizenship Details	Shares
1.
2.
3.

Part 2(c) – Registered Company:

Private or public.....

State the nominal and issued capital of the Company-

Nominal Kshs.....

Issued Kshs.....

Give details of all directors as follows:

Name in full . Nationality. Citizenship Details*. Shares.

1.

2.

3.

4.

Part 2(d) – Interest in the Firm:

Is there any person / persons in(Name of Employer) who has interest in this firm? Yes/No.....(Delete as necessary)

I certify that the information given above is correct.

.....
(Title)

.....
(Signature)

.....
(Date)

Attach proof of citizenship

C: CAPABILITY AND COMPETENCE TO DELIVER GOODS OR SERVICE:

2.6 What products/service do you want to be considered for... ..

2.7 How many employees do you have? How many are Permanent... .. /How many are Temporary?

2.8 What is the country of origin for those goods or services?

2.9 Are you a manufacturer/wholesaler/retailer/other (please specify) (a) If you are a manufacturer or a service organization, are your products certified by the Kenya Bureau of Standards or are you affiliated to a recognized accrediting body? Yes//No. Please attach documentary evidence of the current certification].

(b) If you are not a manufacturer, are you an authorized dealer? Yes0//No... .. please attach documentary evidence of the authority from the manufacturer]

2.10 Who are your major customers/clients and what is their telephone contact? - To what extend is your firm e-enabled with both your suppliers and clients and how do you intend to carryout business with KSG?

2.11 What is the Maximum value of business which you can handle at any one time: K s h s

2.12 If your firm is pre-qualified or awarded the tender, will you abide by the agreed delivery period and supply goods or service within the given specifications by KENYA SCHOOL OF GOVERNMENT? Yes /No?

TENDER-SECURING DECLARATION FORM

(r.22) [The Bidder shall complete this Form in accordance with the instructions indicated]

Date: [insert date (as day, month and year) of Bid Submission]

Tender No.: [insert number of bidding process]

To: [insert complete name of Purchaser]

We, the undersigned, declare that:

1. We understand that, according to your conditions, bids must be supported by a Bid-Securing Declaration.
2. We accept that we will automatically be suspended from being eligible for bidding in any contract with the Purchaser for the period of time of [insert number of months or years] starting on [insert date], if we are in breach of our obligation(s) under the bid conditions, because we – (a) have withdrawn our Bid during the period of bid validity specified by us in the Bidding Data Sheet; or (b) having been notified of the acceptance of our Bid by the Purchaser during the period of bid validity, (i) fail or refuse to execute the Contract, if required, or (ii) fail or refuse to furnish the Performance Security, in accordance with the instructions to tenders.
3. We understand that this Bid Securing Declaration shall expire if we are not the successful Bidder, upon the earlier of
 - (a) our receipt of a copy of your notification of the name of the successful Bidder; or
 - (b) thirty days after the expiration of our Tender.
4. We understand that if we are a Joint Venture, the Bid Securing Declaration must be in the name of the Joint Venture that submits the bid, and the Joint Venture has not been legally constituted at the time of bidding, the Bid Securing Declaration shall be in the names of all future partners as named in the letter of intent.

Signed:

Capacity / title (director or partner or sole proprietor, etc.)

Name:

Duly authorized to sign the bid for and on behalf of: [insert complete name of Bidder]

Dated on day of, [Insert date of signing]

Seal or stamp

Contract Form

THIS AGREEMENT made the _____ day of _____ 20 ____ between KENYA SCHOOL OF GOVERNMENT of P/O/ Box 91 BARINGO, KENYA (hereinafter called "KSG () of the one part and ----- [name of tenderer] of----- [city and country of tenderer] (hereinafter called "the tenderer") of the other part:

WHEREAS KSG invited tenders for certain goods, viz,.....[briefdescription of goods] and has accepted a tender by the tenderer for the supply of those goods in the sum of.....[contract price in words and figures] (hereinafter called "the Contract Price")/

NOW THIS AGREEMENT WITNESSETH AS FOLLOWS:

1. In this Agreement words and expressions shall have the same meanings as are respectively assigned to them in the Conditions of Contract referred to.
2. The following documents shall be deemed to form and be read and construed as part of this Agreement, viz.:
 - (a) the Tender Form and the Price Schedule submitted by the tenderer;
 - (b) the Schedule of Requirements;
 - (c) the Technical Specifications;
 - (d) the General Conditions of Contract;
 - (e) the Special Conditions of Contract; and
 - (f) the Notification of Award by KSG.
3. In consideration of the payments to be made by KSG to the tenderer as hereinafter mentioned, the tenderer hereby covenants with KSG to provide the goods and to remedy defects therein in conformity in all respects with the provisions of the Contract
4. KSG hereby covenants to pay the tenderer in consideration of the rovisionof the goods and the remedying of defects therein, the Contract Price or such other um as may become payable under the provisions of the contract at the times and in the manner prescribed by the contract.

IN WITNESS whereof the parties hereto have caused this Agreement to be executed in accordance with their respective laws the day and year first above written.

Signed, sealed, delivered by.....the (for KSG)

Signed, sealed, delivered by the.....(for.....the tenderer)

In the presence of.....

v) Performance Security Form

To: KENYA SCHOOL OF GOVERNMENT

WHEREAS name of tenderer] (hereinafter called "the tenderer") has undertaken, in pursuance of Contract No. _____ [Reference number of the contract] dated 20 _____ to supply [description of goods] (hereinafter called "the Contract")

AND WHEREAS it has been stipulated by you in the said Contract that the tenderer shall furnish you with a bank guarantee by a reputable bank for the sum specified therein as security for compliance with the Tenderer's performance obligations in accordance with the Contract.

AND WHEREAS we have agreed to give the tenderer a guarantee:

THEREFORE WE hereby affirm that we are Guarantors and responsible to you, on behalf of the tenderer, up to a total of..... [amount of the guarantee in words and figures], and we undertake to pay you, upon your first written demand declaring the tenderer to be in default under the Contract and without cavil or argument, any sum or sums within the limits of [amount of guarantee] as aforesaid, without your needing to prove or to show grounds or reasons for your demand or the sum specified therein.

This guarantee is valid until the _ day of _____ 20 .

Signature and seal of the Guarantors

.....

.....

..... [Name of bank or financial
institution]

.....

[address]

..... [date]

vi) Manufacturer's Authorization Form

To: KENYA SCHOOL OF GOVERNMENT

WHEREAS [name of the
Manufacturer] who are established and reputable manufacturers
of..... [name and/or description of the goods]having factories
at..... [address of factory] do hereby
..... [name and address of Agent]
to submit a tender, and subsequently negotiate and sign the Contract with you
against tender
No..... [reference of the
Tender] for the above goods manufactured by us.

We hereby extend our full guarantee and warranty as per the General Conditions
of Contract for the goods offered for supply by the above firm against this
Invitation for Tenders.

.....

[Signature for and on behalf of Manufacturer]

Note: This letter of authority should be on the letterhead of the Manufacturer
and should be signed by a competent person.

TENDER SECURITY DECLARATION FORM

(To be completed on tenderer's letterhead)

To:

The Director General
Kenya School of Government
Baringo
P.O BOX 91-30400
Kabarnet

We, the undersigned, declare that:

1. We understand that, according to your conditions, bids must be supported by a Tender Securing Declaration.
2. We accept that we will automatically be suspended from being eligible for bidding in any contract with the Purchaser for the period of time of *[insert number of months or years]* starting on *[insert date]*, if we are in breach of our obligation(s) under the bid conditions, because we:
 - (a) have withdrawn our Bid during the period of bid validity specified by us in the Bidding Data Sheet; or
 - (b) having been notified of the acceptance of our Bid by the Purchaser during the period of bid validity, (i) fail or refuse to execute the Contract, if required, or (ii) fail or refuse to furnish the Performance Security, in accordance with the Instructions to Tenderers.
3. We understand this Tender Securing Declaration shall expire if we are not the successful Bidder, upon the earlier of (i) our receipt of a copy of your notification of the name of the successful Bidder; or (ii) twenty-eight days after the expiration of our Bid.
4. We understand that if we are a Joint Venture, the Tender Securing Declaration must be in the name of the Joint Venture that submits the bid. If the Joint Venture has not been legally constituted at the time of bidding, the Tender Securing Declaration shall be in the names of all future partners as named in the letter of intent.

Signed: [insert signature of person whose
capacity are shown] In the capacity of name and legal capacity of person signing
[insert Declaration] the Bid Securing

Name: [insert complete name of
person signing the Tender Securing Declaration]

Duly authorized to sign the bid for and on behalf of: [insert complete name of Bidder]

Dated on _____ day of _____ , _____ [insert date of signing]